

# **Service Information for Bearing Lube Axles**



Your trailer is equipped with the Bearing Lube hub greasing system, along with top quality hubs, spindles, seals and bearings. The following information will acquaint you with the axle assembly and includes product maintenance information.

**TRAILER**  
**BUDDY<sup>®</sup>**  
**PRODUCTS BY** 

*San Marcos, CA ★ Winchester, TN*

## BEARING LUBRICATION

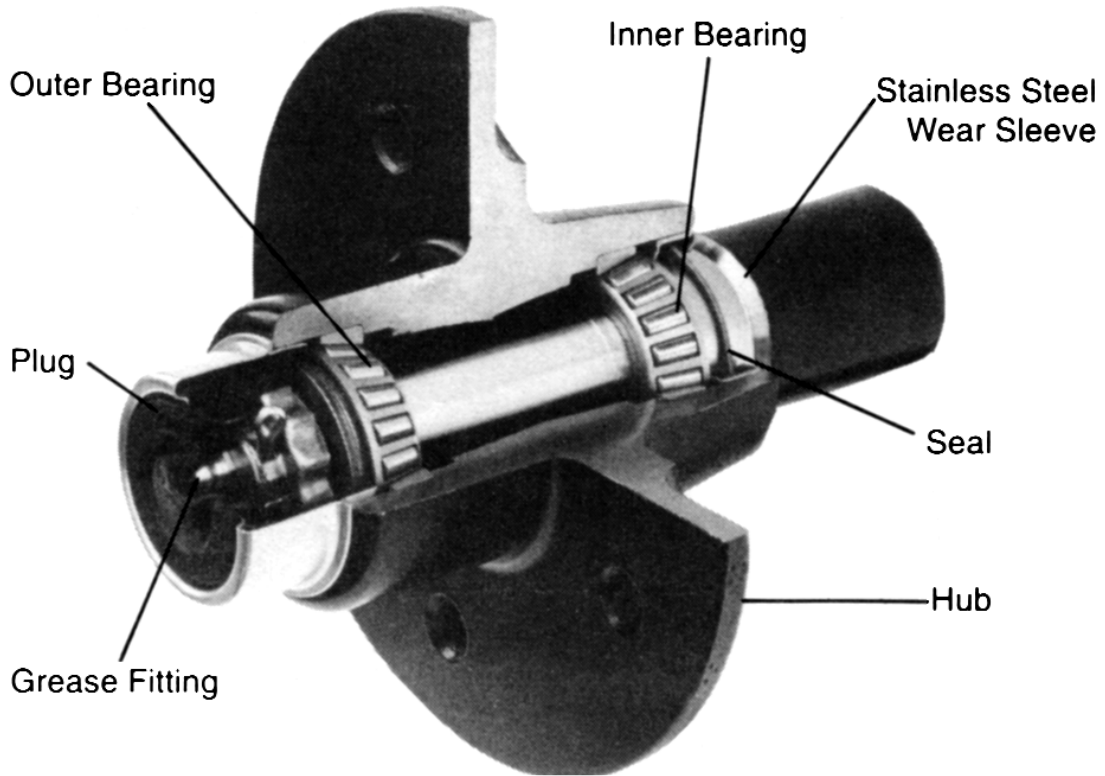

The Bearing Lube system provides an easy way to fill axle hubs and repack bearings with grease to ensure proper bearing lubrication.

To locate the grease (zerc) fitting, simply remove the rubber plug in the hub dust cap. Passages inside the spindle allow grease to flow into the space between the inner bearing and seal. As you add grease, it will flow through the bearings toward the front of the hub. If there is evidence of water around the zerc area, add grease until all contaminated grease is driven out. If the grease is in good condition when inspected, add a small amount of grease until you see grease movement between the hub and spindle.

### WHEN TO GREASE

Grease prior to towing and after launching or retrieval every time. Add grease to expel any water or contaminants that may enter hub cavity during hub submersion. If water enters the hub, wheel bearing damage and failure can occur. **WARNING:** Evidence of water contamination could void warranty. Reference warranty policy.

**NOTE:** Use only a hand operated gun to add lubricant. Adding grease with a power gun can damage seals.

## **RECOMMENDED LUBRICANT**

Use a good quality, EP #2 based grease. Use a water repellent grease if you'd like. Grease consists of oil, soap and additives. Oil sometimes separates from the soap and a small amount may leak under the rear seal. This is normal and won't cause any problems. Select a quality grease and stay with it. Some grease bases aren't compatible with others which can cause the combination to break down.

## **DIAPHRAGM IN DUST CAP PLUG**

The rubber diaphragm may bulge out slightly when the grease-filled hub is hot (a non-brake hub will normally run at 120° to 150° F). This design feature prevents excessive pressure buildup inside the hub.

## **BEARING REPACKING AND INSPECTION**

There is no need to repack bearings in the traditional manner because you achieve the same result by adding grease through the zerc fitting. The new grease entering the hub will push old grease, water and contaminants out the front. If water remains in the hub for extended period of time, you should check bearings to be sure they haven't been damaged.

## **BEARING ADJUSTMENT**

Wheel bearings have been precisely torque set at the factory. To maximize bearing life, we suggest you check bearing adjustment every 2 or 3 years. Jack up one side of the trailer. Grip the edge of the tire on both sides and try to rock or move it. If you can move the outer edge of the wheel more than 1/8" (end play), remove the dust cap, the cotter pin and spindle nut retainer. Tighten the spindle nut to 18-24 inch pounds, which is slightly more than "finger tight". Don't over-tighten. When the nut is positioned properly the wheel should turn easily and there should be no end play (lateral movement) of the hub with respect to the spindle.

To replace the nut retainer, find a position where it will fit over the spindle nut so that the cotter pin can be inserted without having to loosen or tighten the nut. Insert a new cotter pin. Recheck end play. Spread the ends of the cotter pin to keep it in place. Add grease as necessary and replace the dust cap.

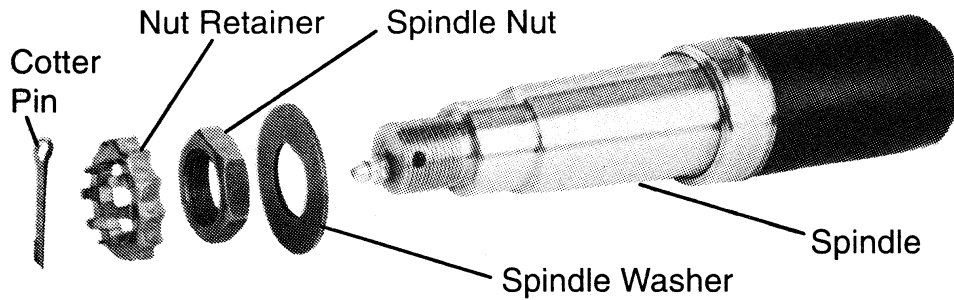

## BEARING SIZES

We use tapered roller bearings identical to those currently being used on many automobiles.

| Axle<br>Load Capacity | Inner  |        | Outer  |        |
|-----------------------|--------|--------|--------|--------|
|                       | Cone   | Cup    | Cone   | Cup    |
| 1200#-2500#           | L44649 | L44610 | L44649 | L44610 |
| 2900#-3750#           | L68149 | L68110 | L44649 | L44610 |



Bearing Cone

## GREASE SEALS

Each hub has a rear (inner) seal which keeps grease from leaking out the back of the hub. The spring loaded seals used on your axle are the best available for the application. The axle spindles are equipped with permanent, polished stainless steel seal surfaces for the seals to rotate on. This system should provide up to 50,000 miles of service (many years of use for most trailers) before seals need to be replaced.

## GREASE LEAKAGE AT REAR SEAL

Visually check seals periodically. No rotating seal is perfect. It's normal to see a film of oil around the seal area. A slight amount of grease leakage won't hurt anything, but if the leakage becomes excessive it's time to eliminate the problem. This usually means disassembling the hub and replacing the seal.

On axles with the drum brakes, you must remove the drum to check the seal condition. If you don't have to add grease to the brake axle, the seal is working properly. On the other hand, if you find you are constantly adding grease or have to add an excessive amount of grease, the seal is probably leaking or the brake is overheating. You should remove the hub-drum and check the brake and seal. Grease leakage can't be tolerated on axles with brakes because if grease gets on brake linings, the brakes won't operate properly and the linings will have to be replaced.

## REPLACING SEALS

The hub or hub drum must be removed from the axle and the seal forced out. It is impossible to remove the seal without damaging it. So if you remove it for some reason, plan on replacing it. Because our seals are a high-quality design not widely available, you will have to obtain a replacement from the dealer, a bearing supply company, the trailer manufacturer or Unique Functional Products.

### Seals currently in use are:

| Axle Load Capacity | Inner Bearing Cone | Hub Bore Diameter | Spindle Shaft Dia. | UFP Seal Part No. |
|--------------------|--------------------|-------------------|--------------------|-------------------|
| 1200#-2300#        | L44649             | 1.98"             | 1.38"              | 198-138-SP1-1     |
| 1200#-2500#        | L44649             | 1.98"             | 1.50"              | 198-150-SP2-1     |
| 2900#-3750#        | L68149             | 2.33"             | 1.68"              | 233-168-SP2-1     |
| 2900#-3750#        | L68149             | 2.56"             | 1.68"              | 256-168-SP2-1     |

## SPINDO® SEAL

Marine dealers stock replacement seal kits manufactured by Unique Functional Products called Spindo Seal. These are replacement seal systems for use on axle spindles NOT manufactured by us. They aren't intended for your equipment (which has a superior seal system).

## WHEEL BOLTS (OR CONE NUTS)

If you remove a wheel from a hub it is very important to properly tighten the wheel bolts (or cone nuts) when you reinstall the wheel.

Mount the wheel on the hub and start the wheel bolts into the hub as far as possible by hand. Then, using a proper lug wrench, tighten each wheel bolt moderately tight. Work your way around the wheel, tightening *every other* bolt until all bolts have been tightened. Then work your way around the wheel again, using the every other bolt sequence, and tighten each bolt 85-95 ft. pounds of torque.

It is important that the wheel be centered on the hub. The wheel may reseal itself during the first miles of travel after installation. After 50-100 miles of travel, check wheel bolt tightness (85-95 ft. lbs.). Check annually thereafter.

DO NOT use impact type wrenches. These can overstress fasteners, causing them to fatigue and break during service.

## BRAKES

The hydraulic drum brakes used are not a self adjusting automotive design. Trailer drum brakes must be adjusted to function properly. Have a qualified professional such as a marine dealer or an automotive service facility adjust your brakes.

Our 10" brake drums have a hole to permit brake lining inspection and access to the brake shoe adjustment star wheel. Remove the trailer wheel if necessary to access the inspection hole.

The brake shoe adjustment star wheel can also be accessed from the back side of the brake. Remove dust cover from the adjusting slot at the lower part of the back side of the brake assembly.

The adjustment procedure is as follows:

1. Insert brake adjusting tool or screwdriver.
2. Adjust brake shoes outward until wheel will not rotate in the forward direction by stroking the end of the adjusting tool toward the top of brake as illustrated.
3. Adjust brake shoes to proper position by stroking end of adjusting tool toward bottom of brake. Suggested proper setting is:

**One set of brakes    10-12 notches**

**Two sets of brakes    5-8 notches**

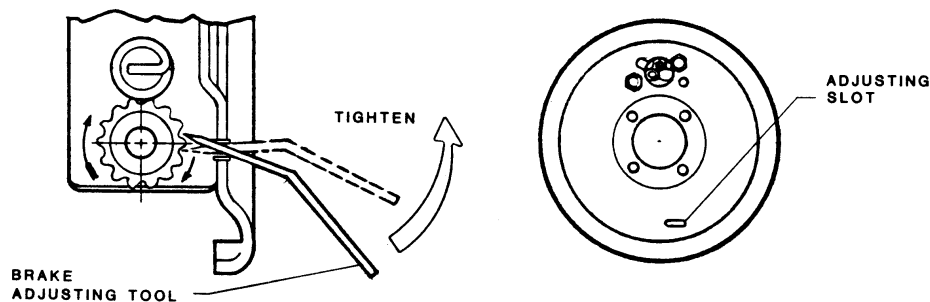

To adjust brake shoes through the hub-drum, stroke the adjusting tool in the **opposite** direction than if adjusting through the brake.

We recommend that trailer brakes be adjusted after the first 300 miles of travel and at least every 2,000 miles thereafter. Poorly adjusted brakes decrease stopping ability. In addition, trailer brakes should be inspected after the first two years of service for wear and corrosion (one year after substantial saltwater immersion). Service, lubricate and /or replace parts as necessary for safe, sure operation. Thereafter, set up a maintenance schedule that assures proper inspection and adjustment of brakes. The time interval should be based on towing conditions, operating environment (salt vs. fresh water, etc.), distance towed, storage conditions, etc. The goal is simple: Make sure your brakes will work properly when you need them most — in an emergency stop.

Self adjusting, ventilated rotor disc brakes are also available on new trailers and as replacements for your existing trailer. Contact your dealer or trailer manufacturer for details.

## REPLACEMENT BRAKE PARTS

The following information is helpful if you wish to buy parts locally.

| <b>Hub-Drum<br/>Bolt Pattern</b> | <b>Brake<br/>Type</b> | <b>Brake Wheel<br/>Cylinder Dia.</b> | <b>FMSI Brake<br/>Shoe Number</b> |
|----------------------------------|-----------------------|--------------------------------------|-----------------------------------|
| 5-Bolt                           | 10" x 2 1/4"          | 1 1/8"                               | 154                               |

1. Wheel cylinder repair kits are available at most auto part stores, Take old wheel cylinder parts with you when buying replacement parts.

2. FMSI stands for Friction Material Standards Institute, an industry group that assigns a number to every brake lining manufactured. Stores selling brake shoes should have a catalog to cross reference their products to an FMSI number.

## BRAKE ACTUATOR

Most trailers use a surge type hydraulic actuator. Make sure it is operating properly and contains sufficient brake fluid. Review the actuator manufacturer's service information.

## BRAKES AREN'T WATERPROOF

Brake manufacturers have taken steps to extend the service life of brakes, but eventually water immersion can cause trouble. Salt water is worse than fresh. If the actuating system operates properly, and the brakes are correctly adjusted but won't work, it's best to check the brake components. Replace any malfunctioning or badly rusted parts. Zinc plated and galvanized brakes are better able to withstand moisture. Disc brakes offer better service life, are easier to inspect and require less maintenance than drum brakes.

## BEARING PROTECTORS

For additional bearing protection, you can install wheel bearing protectors on your axle. Remove the dust cap, check bearing adjustment, and fully grease the hub through the zerc to replace all grease. Remove the zerc. Fill the protector half full of grease and install it into the hub. Check the lubricant level per the wheel bearing protector installation instructions.

A wheel bearing protector offers the advantage of keeping the hub pressurized. The positive internal pressure assures that all moisture is kept out. Wheel bearing protectors permit lubricant level check without removing the dust cap or adding grease.

---

We are confident that our products will contribute to your boating pleasure by eliminating worry and trouble with trailer running gear.

If we can be of assistance or answer any questions, please contact our customer service department.